

# FIREFORCE APPARATUS LTD.



## APPARATUS, SAFETY, MAINTENANCE



# OUR COMMITMENT

---

**Offer Turn Key Apparatus Solutions!!!**

- **DESIGN**
- **BEST CONSTRUCTION FOR APPLICATION**
- **GOOD DELIVERY TIME**
- **SERVICE, SERVICE, SERVICE!!!!**

# WHAT'S NEW??

---

**We now manufacture...**

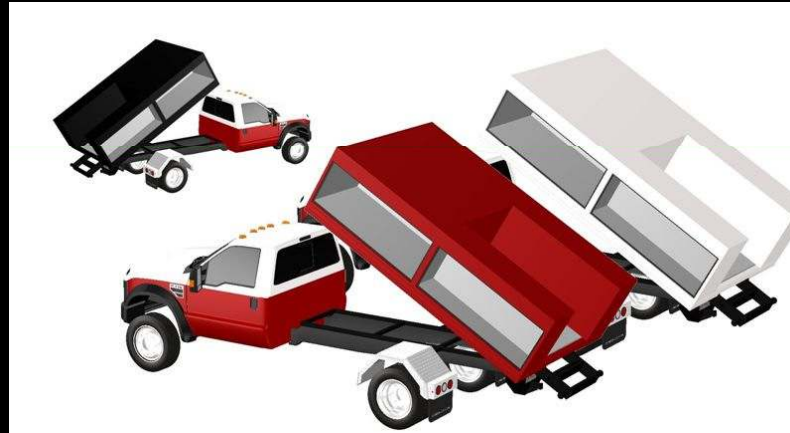
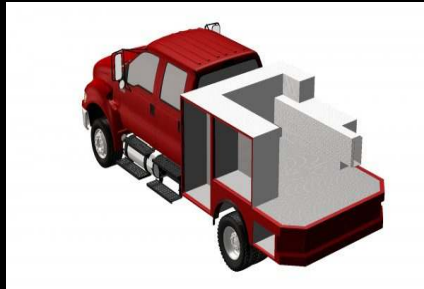

**DESIGNS, VISUAL AIDS IN LESS THAN**

**TWO WEEKS!!!**

# JUST DELIVERED!!



# DECEMBER DELIVERY

---

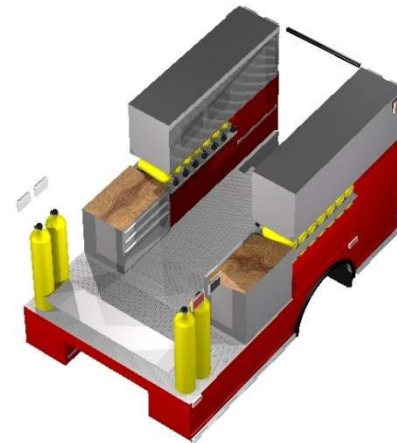

# CASH FLOW



# Today's focus, Big and small flow!!

---



← 20 GPM

← 4000 GPM

# **SUTPHEN**™ ALL OUT.



**Industrial  
Apparatus  
David Rider**

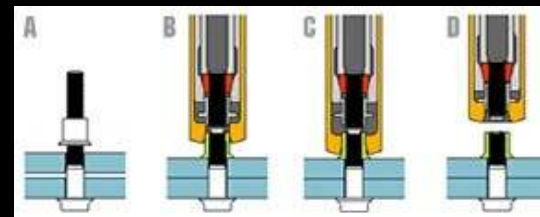

# Tight Areas??? OFF Road Access??

---



# COMPACT APPARATUS



- PATIENT TRANSPORT
- CREW/EQUIPMENT TRANSPORT

- RESCUE
- SUPPRESSION



# HIGH PRESSURE TECHNOLOGY



# HMA- DEVELOPED FOR DND

---



# Successes:

---

- 20 GPM using 21HP Honda V-Twin
- Low level sensors and shutoff
- 1400PSI
- Fast Heat Reduction
- Using Familiar Standard nozzle
- Positive pressure ventilation

# Models:

---

- 100-500 Gallon Skids- Truck mounted
- T4- 4X4 & T6- 6X6 Polaris Ranger
  - 100 gallons w/10 Gallons foam cell
- T4T- 4X4 Tracked UTV Ranger
- 21.5HP Honda Twin Gas HMA pump
- All models come with Foam 0.5-6%
- All models include 150' X  $\frac{3}{4}$ " HP line

# Options:

---

- Diesel
- PTO Hydraulic (Truck only)
- Wildfire Nozzle (Wand Style)
- 100's of Options on Ranger
- Extra  $\frac{3}{4}$ " hose- loss of 25PSI/100'
- Air Suspension all 4 or 6 wheels

# OPTIONS



# RETROFIT

---



# NEW!! BASKET STRETCHER MOUNT



# “Video of Fuel Fire”

---

- 38 gallons diesel/2 gallons gas
- HMA T6 20 GPM @1400PSI
- AFFF foam @ 6% solution
- 9 seconds to extinguish.

# Information

---

## **Call Tony Jumeau:**

-Cell: 604-802-0848

-Toll Free: 888-802-0848

-E-Mail: [info@fireforce.ca](mailto:info@fireforce.ca)